

SYNC SEPARATOR WITH VARIABLE FILTER

DEVICE DESCRIPTION

The ZXFV4583 provides the ability to separate out video synchronisation signals for a wide variety of TV and CRT display systems, standard and non-standard.

Flexibility arises from the use of just three external resistors to adapt to each application. One resistor controls a fully integrated internal colour carrier filter with variable bandwidth. This filter avoids disturbance from the colour carrier, permitting accurate threshold slicing for timing extraction.

A second resistor controls the voltage threshold for loss of signal detection after a time-out interval. The third resistor controls the timing functions.

DC restoration for displays is facilitated by the Back Porch synch output, which can be used to drive an external circuit to clamp the blanking voltage to a fixed level.

ORDERING INFORMATION

Part Number	Container	Increment
ZXFV4583N16TA	Reel 7"	500
ZXFV4583N16TC	Reel 13"	2500

FEATURES AND BENEFITS

- PAL, NTSC, SECAM, other TV systems
- Variable filter for outputs: composite, horizontal, Vertical, back porch, odd / even
- No-signal detector
- On chip sample / hold capacitors
- +5V single supply
- Default vertical output where there are no serration pulses
- Pin compatible with industry standard part SO16N surface mount package

APPLICATIONS

- Digital image capture
- Video input systems requiring separation of picture timing
- Video distribution
- CCTV surveillance
- Digital multimedia
- Timing for black level clamp

CONNECTION DIAGRAM

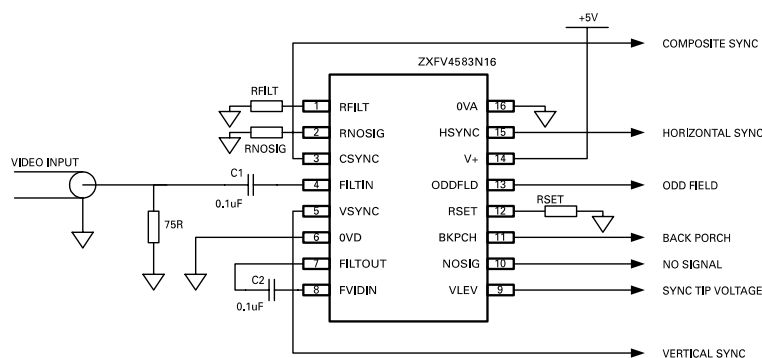

ZXFV4583

ABSOLUTE MAXIMUM RATINGS

Supply voltage VCC	-0.5V to +7V
Inputs to ground*	-0.5V to VCC +0.5V
Operating Temperature Range	-40°C to 85°C Storage -65°C to +150°C

Operating Ambient Junction temperature T_{JMAX}150°C**

**The thermal resistance from the semiconductor die to ambient is typically 120°C/W when the SO16 package is mounted on a PCB in free air. The power dissipation of the device when loaded must be designed to keep the device junction temperature below T_{JMAX}.

*During power-up and power-down, these voltage ratings require that signals be applied only when the power supply is connected.

ELECTRICAL CHARACTERISTICS

V_{CC} = 4.75 TO 5.25, R_{SET} = 680k, R_{FILT} = 22k, R_{NOSIG} = 82k, T_{amb} = 25°C unless otherwise stated.

PARAMETER	CONDITIONS	TEST	MIN	TYP	MAX	UNIT
DC Characteristics						
Supply current		P		4.5		mA
Clamp voltage	Pin 4 unloaded	P	1.3	1.35	1.8	V
Discharge current at FILTIN	Pin 4, Vin = 2V pk-pk	C		1		μA
Discharge current at FILTIN	Pin 4, no signal	P	3	6	12	μA
Clamp charge current at FILTIN	Pin 4, Vin = 1V pk-pk	P	2	3	4	mA
Clamp voltage at FVIDIN	Pin 8 unloaded	P	1.3	1.35	1.8	V
Discharge current at FVIDIN	Pin 8, Vin = 2V pk-pk	C		1		μA
Discharge current at FVIDIN	Pin 8, no signal	P	3	6	12	μA
Clamp charge current at FVIDIN	Pin 8, Vin = 1V pk-pk	P	2	3	4	mA
R _{SET} voltage, pin 12		P	1.5	1.75	2	V
R _{FILT} voltage, pin 1		P	0.35	0.5	0.65	V
R _{NOSIG} current, pin 2		P	1.5	2.5	3.5	μA
Logic output Low voltage, V _{OL}	I _{OL} = 1.6mA	P		0.35	0.8	V
Logic output High voltage, V _{OH}	I _{OH} = 1.6mA	P	2.4	4		V

TEST - P = production tested, C = characterised



PROVISIONAL ISSUE C - NOVEMBER 2002

ZXFV4583

ELECTRICAL CHARACTERISTICS (CONT)

VCC = 4.75 TO 5.25, R_{SET} = 681k, R_{FILT} = 22k, Tamb = 25°C unless otherwise stated.

PARAMETER	CONDITIONS	TEST	MIN	TYP	MAX	UNIT
AC Characteristics						
FILTIN function input voltage range	PAL/NTSC	P	0.4		2	V pk-pk
Filter voltage gain	FILTIN to FILOUT	P		6		dB
Filter attenuation	4.4MHz for PAL, 3.6MHz for NTSC	C C		t.b.a 12		dB dB
Slice level	Vin = 1V pk-pk	P	40	50	60	%
CSYNC prop. Delay, t _{CS}	Relative to pin 4 input	P		250	400	ns
VSYNC delay		P		250		ns
VSYNC pulse width, t _{VSYNC} (PAL)		P		165		µs
VSYNC pulse width, t _{VSYNC} (NTSC)		P		195		µs
VSYNC default delay, t _{VSD}		P	27	36	45	µs
HSYNC delay		P		250		ns
HSYNC pulse width, t _{HSYNC}		P	3.8	5	6.2	µs
BKPCH delay, t _{BD}	Relative to pin 4 input	P		250	400	ns
BKPCH pulse width, t _B		P	2.7	3.7	4.7	µs
VLEV output	Input 1 Vpk-pk, pin 4	P	500	600	700	mV
NOSIG time-out delay after loss of signal		P	400	600	800	µs

TEST - P = production tested, C = characterised

ZXFV4583

CONNECTIONS

PIN No.	PIN NAME	TYPE	FUNCTION
1	RFILT	Resistor control	Controls the input colour carrier filter characteristic. An external resistor R_{FILT} connected from this pin to 0V sets the bandwidth. Smaller R_{FILT} gives increased bandwidth. See the detailed operating description below.
2	RNOSIG	Resistor control	Controls the no-signal detector level. An external resistor R_{NOSIG} connected from this pin to 0V sets the threshold voltage level, according to the equation $V_{PMIN} = 0.75 R_{NOSIG} / R_{SET}$ where V_{PMIN} is the minimum detected sync pulse amplitude at pin 4 and R_{SET} is the resistor value at pin 12.
3	CSYNC	Logic out	Composite sync logic output. Includes all sync pulses derived from the input video.
4	FILTIN	Analog in	Input to colour carrier filter. This is the main analog (unfiltered) composite video input used when colour carrier filtering is required. A voltage clamp circuit and adaptive current source are also included at this node. See the detailed operating description. When the filter is not used, this pin must be left open circuit.
5	VSYNC	Logic out	Vertical sync output. This is an active low pulse commencing on the first vertical sync pulse trailing (rising) edge and ending near the second next equalising pulse. See timing diagram.
6	OVD	Ground	Provides ground return path for internal logic output buffer circuits. Normally connected externally to a common PCB ground plane.
7	FILTOUT	Analog out	Analog output signal from colour carrier filter. The filter voltage gain is nominally 2. This output is normally capacitor-coupled to pin 8.
8	FVIDIN	Analog in	Input for filtered analog video signal input. This is the direct input to the sample/hold and sync slicing comparator providing the logic timing edges. This input is normally coupled via an external capacitor from FILTOUT, pin 7. It may be used as the signal input where the colour carrier filter is not required. Includes a clamp similar that of pin 4.
9	VLEV	Analog out	Analog output, a positive voltage typically equal to twice the (negative) peak sync pulse amplitude if the filter is used.
10	NOSIG	Logic out	Logic output, which goes high after a time-out delay when no signal is present. The threshold level is controlled at pin 2.
11	BKPCH	Logic out	Burst or Back Porch logic output, an active low monostable pulse triggered from rising composite sync pulse edges. The width is set by R_{SET} to overlap most of the steady part of the back porch, assuming the colour carrier burst has been attenuated sufficiently by filtering. This pulse is then suitable for controlling an external black level clamping circuit. See the timing diagram.
12	RSET	Resistor control	Controls the timing interval of the sample/hold circuit and the monostable interval for the sync outputs according to the application. An external resistor, R_{SET} connected from this pin to 0V establishes the timing parameter, to which these times are scaled together. See the detailed operating description.
13	ODDFLD	Logic out	Odd field logic output. High during an odd numbered field, low during even. This output is timed with the start of the VSYNC pulse.
14	V+	Power in	Power supply input, +5V.
15	HSYNC	Logic out	Horizontal sync logic output. Monostable output derived from CSYNC falling edges, it achieves a steady stream of 5 μ s pulses. The half line events during the field blanking interval are eliminated. See timing diagram.
16	OVA	Ground	Analog ground. Normally connected externally to a common PCB ground plane.

DETAIL DESCRIPTION

Introduction

This device includes all the functions required to separate out the critical timing points of most types of video signal. A sample-and-hold process is used to establish accurately the 50% point of the sync pulse. The input is also filtered to avoid the effect of the colour carrier. The filter is coupled externally. The following paragraphs give a simplified description of the signal processing.

Colour Carrier Filter

This is a low-pass filter providing adjustable attenuation of the colour carrier with low distortion of the remaining sync pulses so as to ensure accurate timing of the extracted logic outputs. The control is via an external resistor **R_{FILT}** connected from pin 1 to ground. A graph shows how the bandwidth varies with the resistor value (Graph to be provide in future issue).

Clamping Circuits

Clamping circuits are use to limit the signal swing excursion after AC coupling at both the input to the filter, **FILTIN** and the timing extractor input, **FVIDIN**. In each case, the sync tip level is maintained at a value of nominally 1.35V.

Sync Timing Extraction Circuits

The waveforms are depicted in Timing Diagrams, **Figure 1** for PAL (625 lines) and **Figure 2** for NTSC (525 lines). Sample-and-hold circuits are used to obtain time-delayed voltage values of the sync tip and the back porch. The sample gates are controlled by a comparator sensing the video input relative to a threshold at a fixed offset above the sync tip clamp level. The sampled voltages are combined in a potential divider to derive the mean voltage (50% amplitude), which is used as the sync pulse threshold. A second comparator then provides **CSYNC**, the logic version of the composite sync signal. This is delayed slightly as shown in **Figure 3**. The time delay comprises that of the input filter and also the smaller delay of the comparator and logic. The timing of the sample hold and other time parameters are all controlled together in unison by the external resistor **RSET**. A 1% resistor tolerance is recommended. The sync tip voltage level from the sample-and-hold is buffered and provided as an analog output, **VLEV**.

The vertical sync output **VSYNC** is derived from the Field pulse group. Where there are short equalisation pulses in the standard systems, these short pulses are ignored. Essentially, a pulse width discriminator circuit senses the first of the Field pulses, as they are wider than those of the rest of the sequence. The trailing edge of the first negative-going Frame Pulse (i.e. the rising edge of the first "serration" pulse) triggers the **VSYNC** output. In systems with a frame interval with no serration pulses, a vertical sync output is provided after a default delay as in **Figure 4**. Also provided is an **ODDFLD** logic output, which is high during an odd-numbered field and low during an even one.

The horizontal sync **HSYNC** is a monostable output derived from the leading edge of the composite sync. The pulse width is about 5 μ s. Also, during the Field blanking sequence, the additional half-line pulses are removed by a timing circuit with a pulse interval discrimination function controlled by **RSET**.

The Back Porch monostable output **BKPCH** is initiated from the trailing edge of the composite sync. The pulse is active low and the width is set according to **RSET**.

Loss-of-Signal Detector

Loss of signal is indicated by a logic high level at the output **NOSIG**. The decision threshold is set by an external resistor **RNOSIG** connected from pin 2 to ground. The table of connections above gives the equation used to determine a suitable resistor value. A waiting time of nominally 600 μ s occurs before the loss of signal is flagged.

ZXFV4583

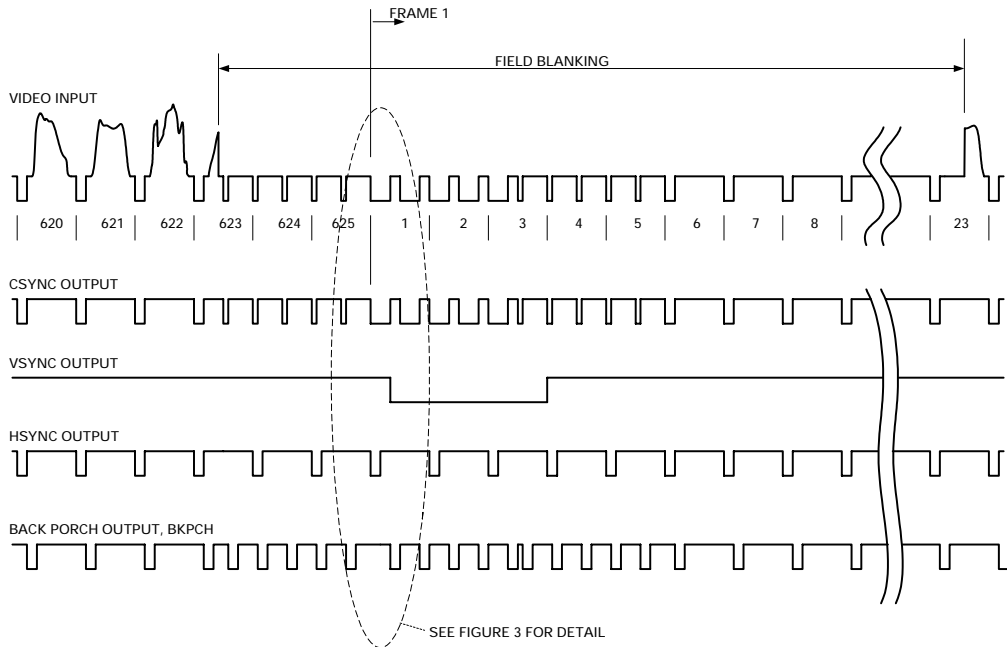

Figure 1: PAL 625 TIMING DIAGRAM

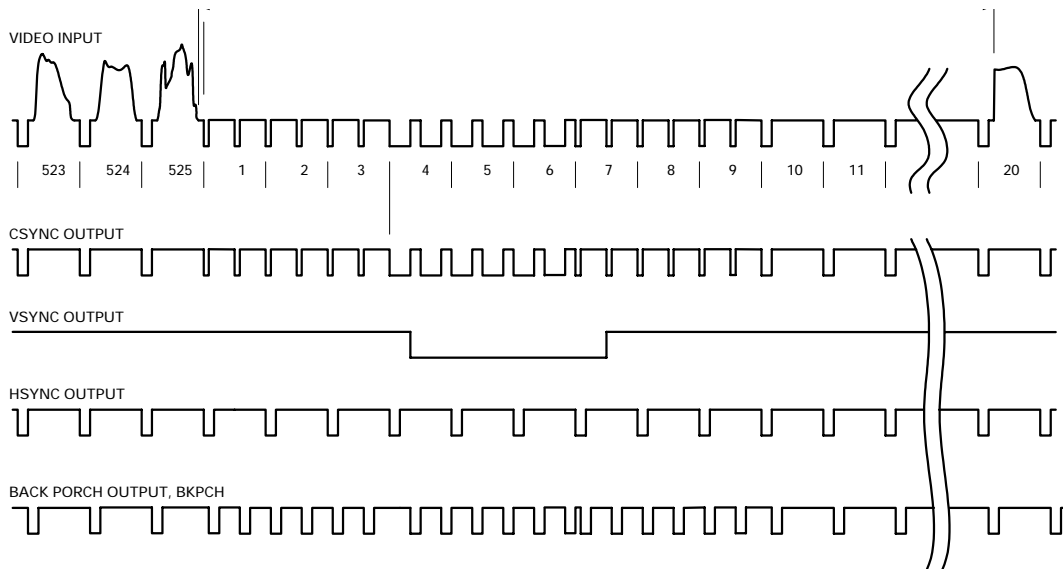

Figure 2: NTSC TIMING DIAGRAM

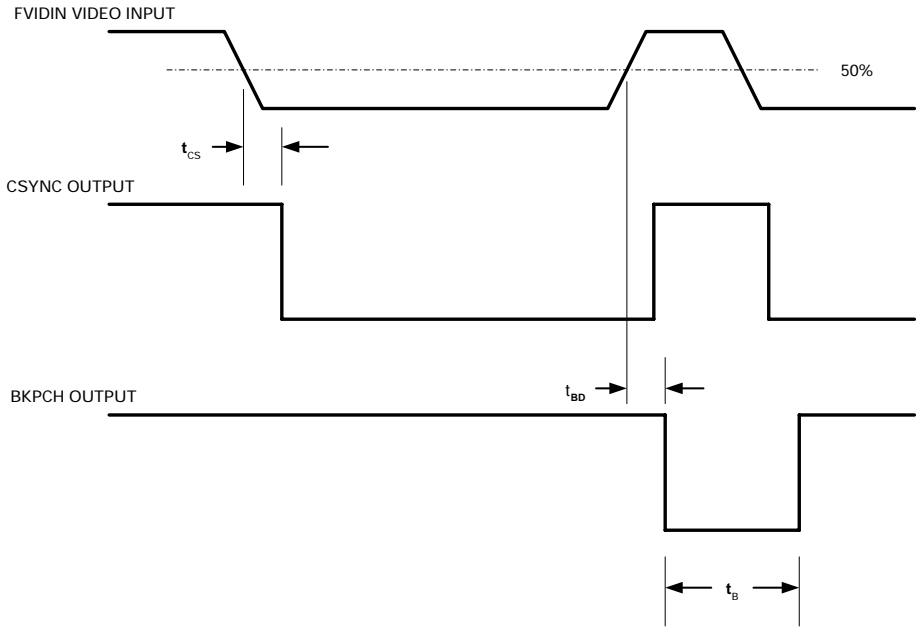

Figure 3: SYNC SLICING & OUTPUT DETAIL

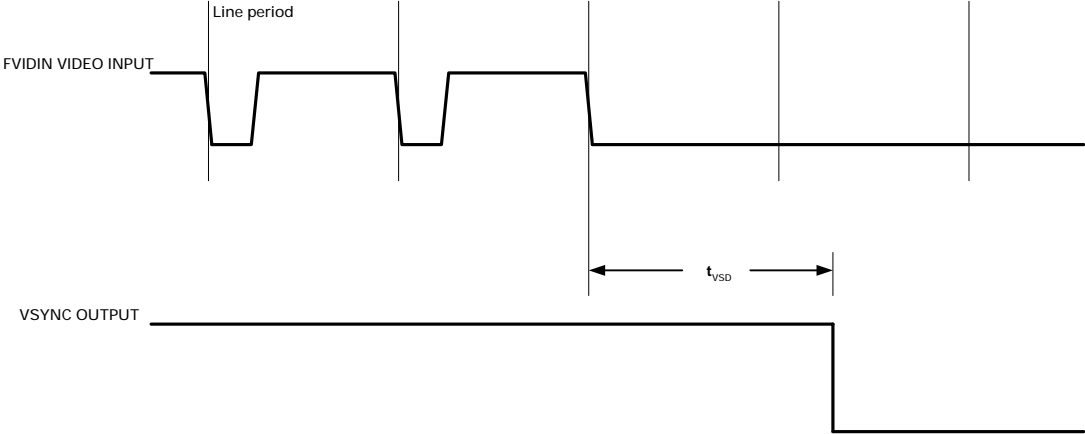
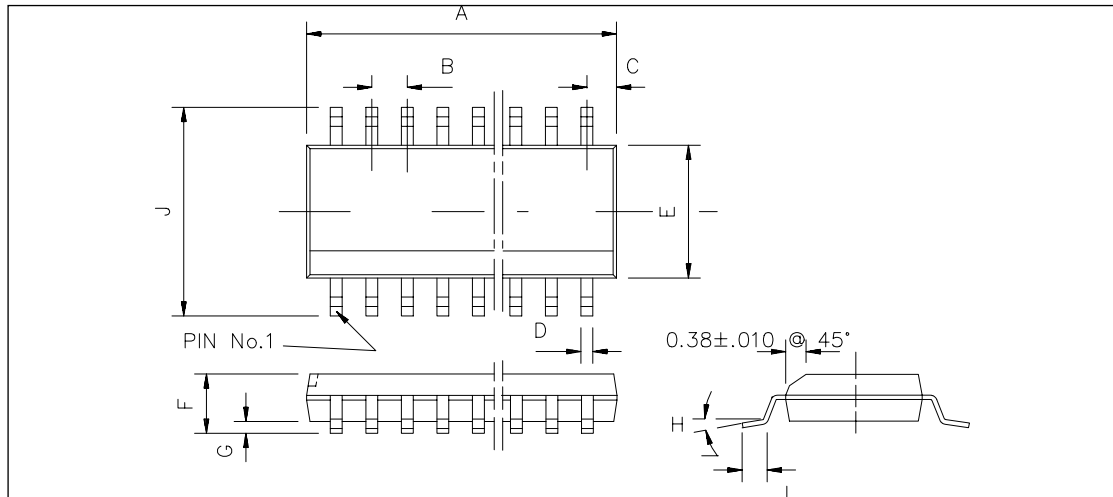

Figure 4: VERTICAL SYNC DEFAULT

ZXFV4583

PACKAGE OUTLINE



DIM	Millimetres		Inches	
	MIN	MAX	MIN	MAX
A	9.80	10.00	0.386	0.394
B	1.27 BSC		0.05 BSC	
C	0.53 REF		0.02 REF	
D	0.33	0.51	0.013	0.020
E	3.80	4.00	0.15	0.157
F	1.35	1.75	0.053	0.069
G	0.10	0.25	0.004	0.01
H	0°	8°	0°	8°
I	0.40	1.27	0.016	0.05
J	5.80	6.20	0.228	0.244

Conforms to JEDEC MS-012AC Iss C (SO16N)

© Zetex plc 2002

Europe		Americas	Asia Pacific
Zetex plc Fields New Road Chadderton Oldham, OL9 8NP United Kingdom Telephone: (44) 161 622 4422 Fax: (44) 161 622 4420 uksales@zetex.com	Zetex GmbH Streitfeldstraße 19 D-81673 München Germany Telefon: (49) 89 45 49 49 0 Fax: (49) 89 45 49 49 49 europe.sales@zetex.com	Zetex Inc 700 Veterans Memorial Hwy Hauppauge, NY11788 USA Telephone: (631) 360 2222 Fax: (631) 360 8222 usa.sales@zetex.com	Zetex (Asia) Ltd 3701-04 Metroplaza, Tower 1 Hing Fong Road Kwai Fong Hong Kong Telephone: (852) 26100 611 Fax: (852) 24250 494 asia.sales@zetex.com

These offices are supported by agents and distributors in major countries world-wide.

This publication is issued to provide outline information only which (unless agreed by the Company in writing) may not be used, applied or reproduced for any purpose or form part of any order or contract or be regarded as a representation relating to the products or services concerned. The Company reserves the right to alter without notice the specification, design, price or conditions of supply of any product or service.

For the latest product information, log on to www.zetex.com



PROVISIONAL ISSUE C - NOVEMBER 2002